



**Techni**  
ENGINEERING SOLUTIONS

**NISSAN / RENAULT / VAUXHALL  
NV400 / MASTER , MOVANO  
2.3 DCI / CDTI - FWD**

---

**CODE / CODICE: 0500.7632**

**COMPRESSOR / COMPRESSEUR / KOMPRES-  
SOR / COMPRESSORE / COMPRESOR :  
SELTEC: TM13, TM15  
QUE: QP13, QP15**

---

**FITTING INSTRUCTIONS  
EINBAUANLEITUNGEN  
INSTRUCTIONS POUR LE MONTAGE  
ISTRUZIONI DI MONTAGGIO  
INSTRUCCIONES DE MONTAJE**

---



**Contents**

<b>ENGLISH</b> .....	4
Parts View.....	4
Parts List .....	5
Finish .....	5
Compressor Configurations .....	6
Standard Fastener Torque Values .....	6
Kit Details .....	7
Vehicle Details.....	7
Forward .....	7
Pre Installation.....	8
Installation .....	8
Compressor Installation.....	8
Drive belt Installation .....	9
Electrical Interface .....	10
Finish .....	10

PARTS VIEW / VUE ÉCLATÉE / TEILEANSICHT / VISTA PARTA / IMÁGENES DE LAS PIEZAS

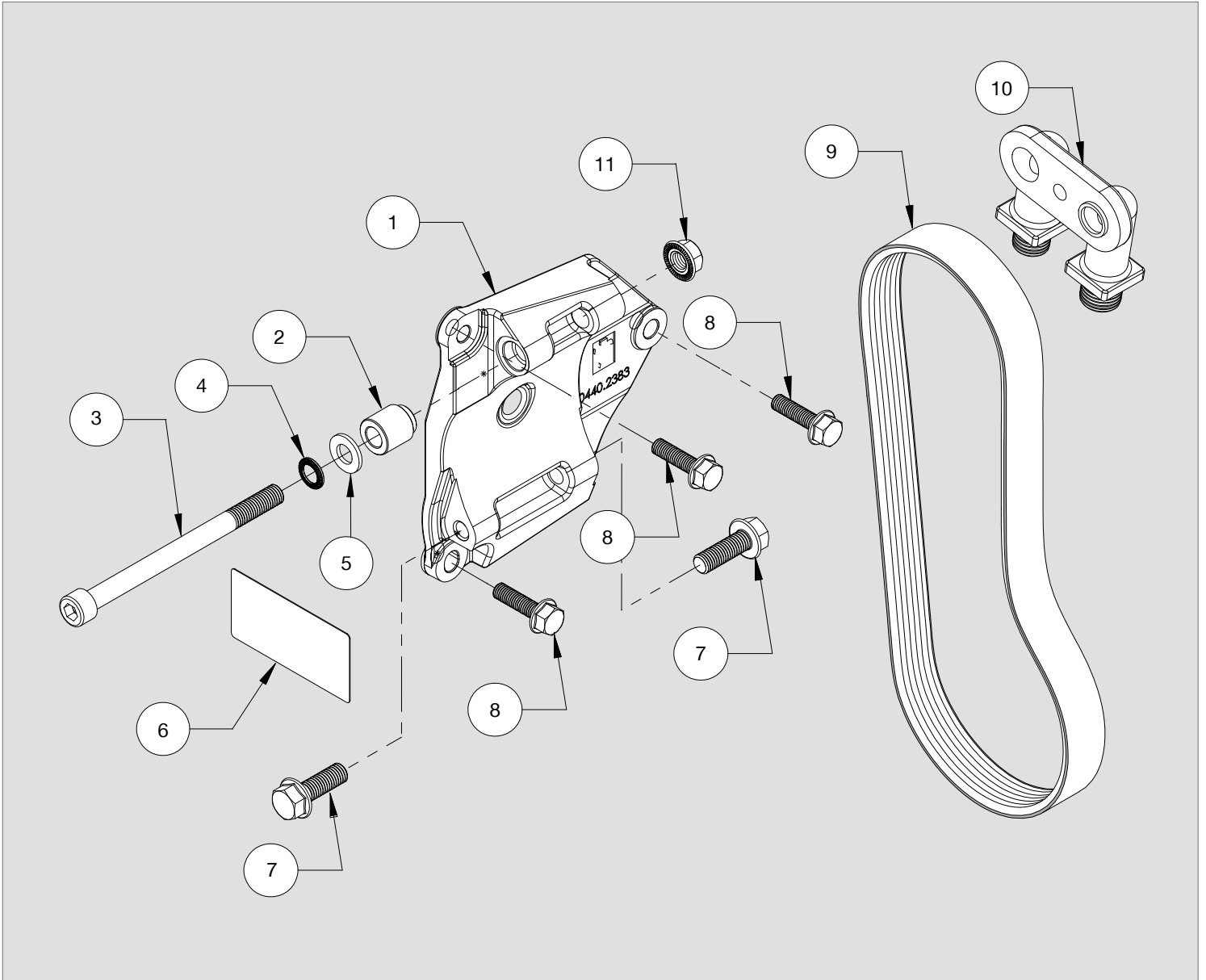

## PARTS LIST / NOMENCLATURE / TEILELISTE / ELENCO DELLE PARTI / LISTA DE PIEZAS

ITEM	CODE / CODICE / KODE / CODIGO	DESCRIPTION / DESCRIZIONE / BESCHREIBUNG / DESCRIPCION	QTY.	COMMENTS
1	0440.2383	Compressor Mount Bracket	1	-
2	2803.3403	Compressor Spacer	1	-
3	2705.0301	Cap Screw M10 x 130	1	-
4	2809.0101	M10 Schnorr Washer	1	-
5	2809.0011	M10 Washer	1	-
6	2902.4372	Warning Label	1	-
7	2705.0491	M10 x 30 Set Screw	2	-
8	2704.0091	M8 x 30 Set Screw	3	-
9	0820.7381	Drive belt 7PK 1705	1	
10	0425.0371	Seltec Inverted Manifold	1	-
11	2735.0071	M10 Locking Nut	1	-

**COMPATIBLE COMPRESSORS / COMPRESSEURS RECOMMANDÉS / EMPFOHLENE KOMPRESSOREN  
RACCOMANDATO COMPRESSORI / RECOMENDADAS COMPRESORES**

SELTEC	TM-13 HS	TM15-HS	-
Comp No	0381.0152	0381.0802	-
Valeo No.	10354320	10355320	-
Mounting	Ear	Ear	-
Rotor	8PV	8PV	-
Armature	SL	SL	-
Diameter	123	123	-
Voltage	12	12	-
Orientation	V	V	-
Fitting	3/4 x 7/8	3/4 x 7/8	-
Manifold	Bolt	Bolt	-

QUE	QP13 HD	QP15 HD	-
Comp No	0391.0152	0391.0802	-
Que No.	QP13-1235	QP15-1761	-
Mounting	Ear	Ear	-
Rotor	8PV	8PV	-
Armature	SL	SL	-
Diameter	123	123	-
Voltage	12	12	-
Orientation	V	V	-
Fitting	3/4 x 7/8	3/4 x 7/8	-
Manifold	Bolt	Bolt	-

DELPHI	-	-	-
Comp No.	-	-	-
Delphi No.	-	-	-
Mounting	-	-	-
Rotor	-	-	-
Armature	-	-	-
Diameter	-	-	-
Voltage	-	-	-
Orientation	-	-	-
Fitting	-	-	-

Notes

**STANDARD FASTENER TORQUE VALUES**

In the absence of specific torque values detailed in this fitting instruction manual, the following chart can be used as a guide to the maximum safe torque for specific size and grade of fastener.

**COUPLES DE SERRAGE DES FIXATIONS STANDARDS**

Si des chiffres de serrage au couple particuliers ne sont pas indiqués dans cette notice de montage, se référer au tableau suivant qui servira de guide pour le couple de sécurité maximum correspondant à une taille et un grade spécifiques de fixation.

**ANZIEHMOMENTE FÜR STANDARDBEFESTIGUNGSMITTEL**





Falls in dieser Einbauanleitung keine speziellen Anziehmomente angegeben sind, kann die folgende Tabelle als Richtlinie für das maximale sichere Anziehmoment für eine spezifische Größe oder Qualität von Befestigungsmitteln dienen.

**VALORI STANDARD DI SERRAGGIO PER DISPOSITIVI DI FISSAGGIO**

In assenza di valori specifici di coppia nel presente manuale di istruzioni, si può utilizzare la seguente tabella come guida per conoscere la coppia massima sicura in base a dimensioni e grado del dispositivo di fissaggio.

**VALORES ESTÁNDAR DE LOS PARES DE APRIETE Y FIJACIÓN**

En ausencia de valores para los pares de apriete específicos detallados en este manual de instrucciones de montaje, se puede utilizar la siguiente tabla como guía para consultar el máximo par de torsión seguro para un tamaño concreto y su grado de fijación.

STRENGTH								
	Max Torque		Max Torque		Max Torque		Max Torque	
Dia / Pitch	lb.ft	Nm	lb.ft	Nm	lb.ft	Nm	lb.ft	Nm
M5 x 0.80	2	3	4.5	6	6.5	9	7.5	10
M6 x 1.00	4	5.5	7.5	10	11	15	13	18
M8 x 1.25	10	13	18	25	26	35	33	45
M10 x 1.25	20	27	39	53	57	78	66	90
M10 x 1.50	18	25	37	50	55	73	63	86
M12 x 1.75	33	45	63	85	97	130	111	150
M14 x 2.00	55	75	103	140	151	205	177	240
M16 x 2.00	85	115	159	215	232	315	273	370

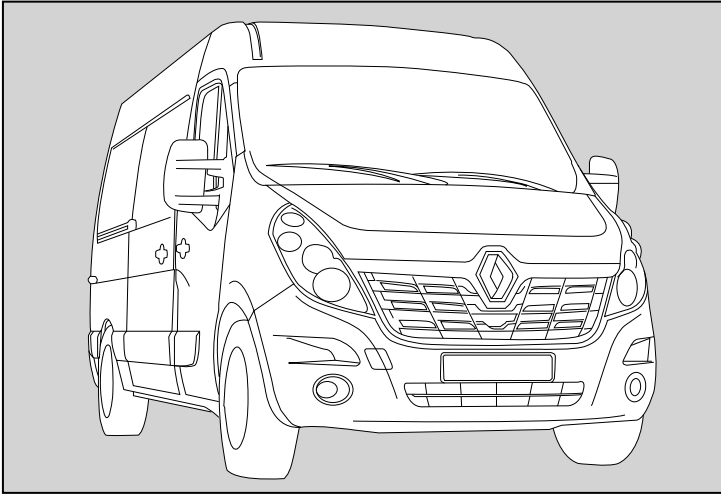

## VEHICLE DETAILS

Manufacturer	Nissan / Renault / Vauxhall
Make	NV400 / Master , Movano
Model	2.3 dCi / CDTi - FWD
Engine	135/165 PS (2299CC)
Engine Details	M9T
Year	2014>
Chassis Nos.	N/A
LHD	YES
RHD	YES
PAS	YES
A/C	NO
Voltage	12v

## KIT DETAILS

Kit Part No.	0500.7632
Description	Standard Kit
Compressor RPM	4441 @ Max Engine
	Power Output
Fitting Time	45 Minutes
Suction Fitting	90°
Discharge Fitting	90°
Belt Type	7PK 1705
Belt Part No.	0820.7381
Note: Not compatible with: Tecshift/Quickshift/Automatic/Robotised Gearbox options. Vehicles with Start/Stop require the battery interface option: CABADP / KPD	

## FOREWORD

The purpose of this manual is to facilitate the installation of a direct drive compressor. The information given is merely instructive, should any complications arise contact the Technical department. The manufacturer's warranty does not cover any problems caused by defective installation or alterations made unless authorised. The manufacturer shall not be responsible for any injury, damage or loss caused directly or indirectly as a result of using this manual or the information contained within it.

### 1 SAFETY MEASURES:

**Before fitting the Compressor adapter drive kit, ensure the following for damage:**

- a Inner and outer trim and body work
- b Engine idle pace
- c Check all the vehicle functions

**Check list:**

- a Ensure that the right kit has been selected
- b Before installing, check that all the correct pieces are present; also ensure that there are no missing or broken pieces
- c When fitting, make sure the vehicle is properly protected against damage.

### Installation apparatus

- a Calibrated torque wrench
- b Hand service tools
- c Protective covers and shields

### 2 PRECAUTIONS

- a Detach the battery negative lead.
- b Torque all bolts where stated using a calibrated torque wrench.
- c Take extreme care with moving parts.
- d Remove the vehicle's ignition key and keep it with you.
- e Wear safeguards and make sure that liquid refrigerant never touches your skin

**Caution:** Measures must be followed accurately to steer clear of the possibility of damage to individuals

**Warning:** This calls awareness to actions which must be pursued to avoid damage to the components.

**NB:** This calls awareness to make the job easier or gives useful information.

**N.B** Prior to commencing work, please examine the instructions with care. The alphabetical symbols on the diagram relate to written instructions, numerical symbols relate to the parts listing.

### PRE-INSTALLATION

#### Remove the following parts:

1. Take off and discard the original drive belt (A) - Fig 1

Please take note how the original belt is configured.

Unscrew the M8 bolts (B) holding the original idle pulley assembly (C) - Fig 1

2. Dispose of the original bolts (B) and pulley assembly (C) - Fig 1

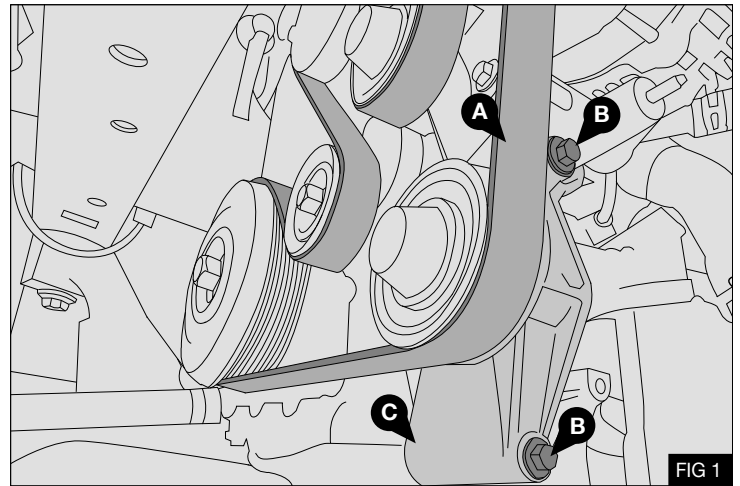

### INSTALLATION

3. Install the supplied bracket (1) using bolts (8) - Fig 2

4. Torque M8 x 30 bolts (8) to 29Nm / 21.4Lb ft - Fig 2

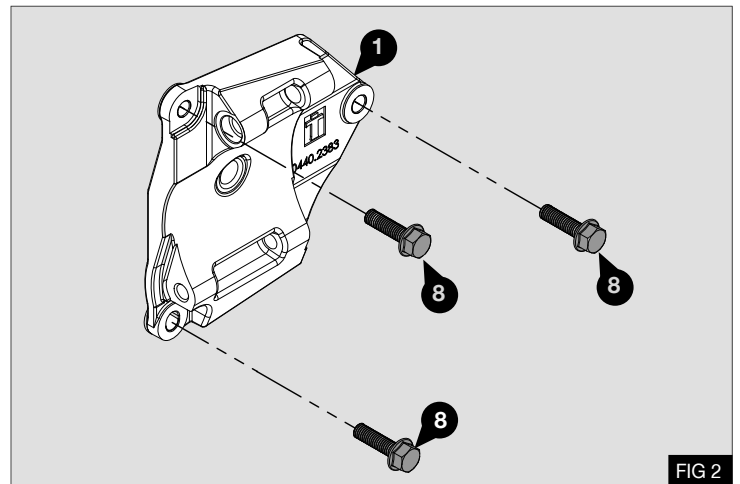

5. Install the spacer (2) as shown in - Fig 3

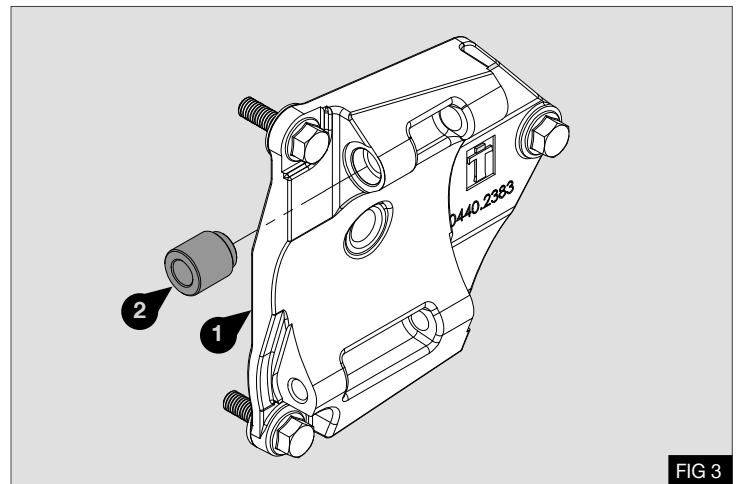

### COMPRESSOR INSTALLATION

1. Install the inverted manifold (10) to the compressor using original bolt (F) - Fig 4

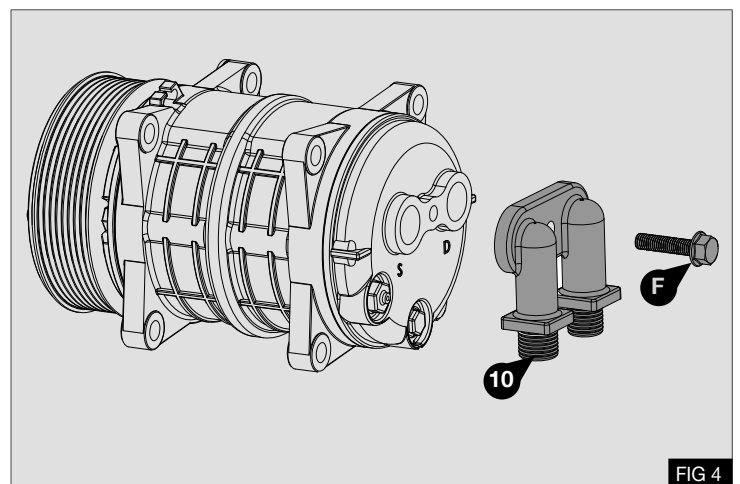



2. Attach the compressor to the mount bracket ① by bolt ③ flat and locking washer ④, ⑤ and nut ⑪.  
Attach the base the compressor with bolts ⑦ - Fig 6
3. Torque M10 x 130 bolt ③ to 63Nm / 46Lb ft - Fig 5
4. Torque M10 x 30 bolts ⑦ to 58Nm / 43Lb ft - Fig 5

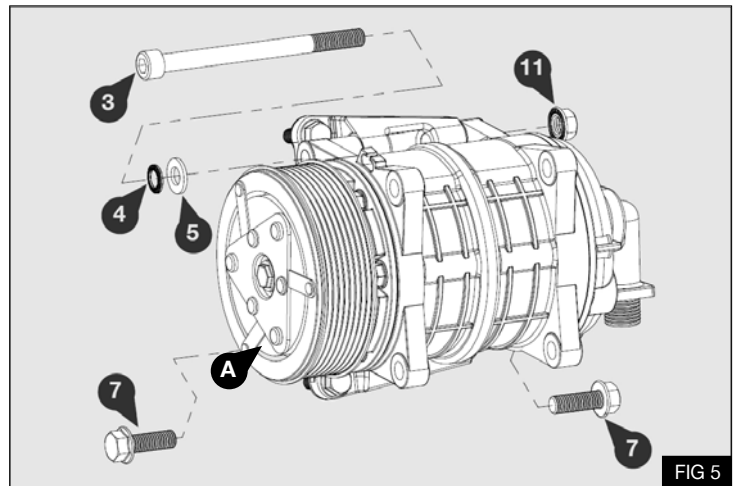

### DRIVE BELT

1. Fit the supplied drive belt ⑨ to the vehicle - Fig 6
2. A – Crank Pulley  
B – Tensioner Pulley  
C – Water Pump  
D – Idle Pulley  
E – Alternator  
F – AC compressor

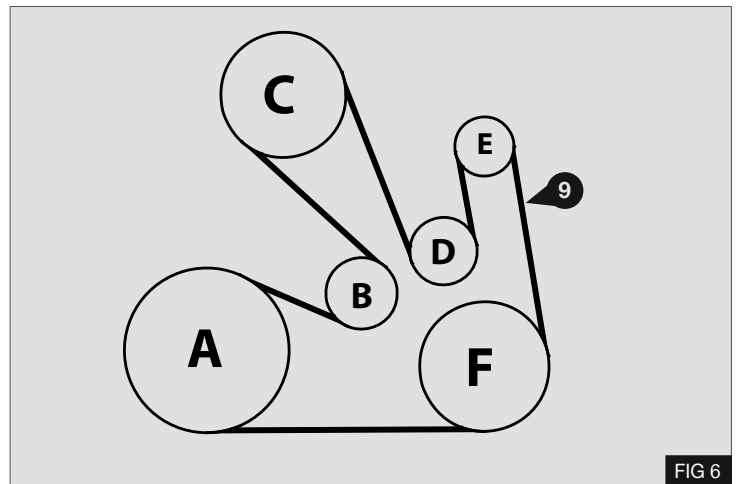

3. Place the belt in the correct groove of the compressor - Fig 7

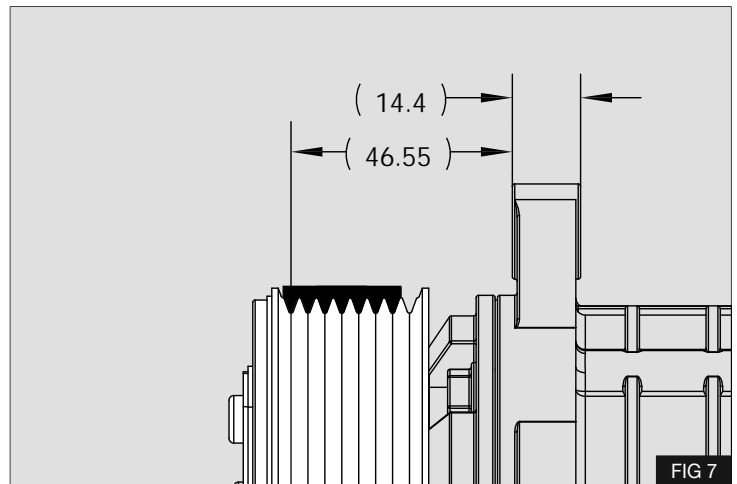

**ELECTRICAL INTERFACE**

1. Vehicles fitted with Stop / Start technology must have the fast idle activated when combined with this compressor mount kit.
2. Full details of how to complete this operation are contained within the Renault / Vauxhall / GM conversion guidelines for this vehicle in the following locations :-

**Renault** - 4.11 "CABADP" option / fast idle "RALENT" option

**Vauxhall** – 4.11 wiring loom for conversions option "KPD" / fast idle option "UF3"

3. The fast idle is activated by connecting pin 1 of the 6 way connector to earth – Fig 8
4. Location of the 6 way connector - The connector is located on the left-hand side of the dashboard, near to the panel feed-through ring, the passenger compartment fuse and relay box and the bonnet opening lever. It is secured on the dashboard wiring by a tie. Extra length is provided for the connection. The connector is in the same position for both left-hand and right-hand drive vehicles.
5. Manufacturers recommend that this connection is activated whenever the refrigeration / additional AC system is active
6. Manufacturers also provide a +12v battery power supply for use with auxiliary component wiring. This is a 2 way connector located behind the B-pillar trim.

**Note:** This power supply is connected directly to the battery (via fuse F6) and is therefore not protected by the energy management system. Therefore there is a risk of battery discharge.

**POST INSTALLATION**

1. Run the engine with compressor engaged for five minutes. Check all components.
2. Check the belt tension when the belt is hot. It is important that the belt is allowed to cool before re-tensioning. **Always re-tension new belts if the tension is less than the used belt amount.** Install the supplied belt label in the engine bay.

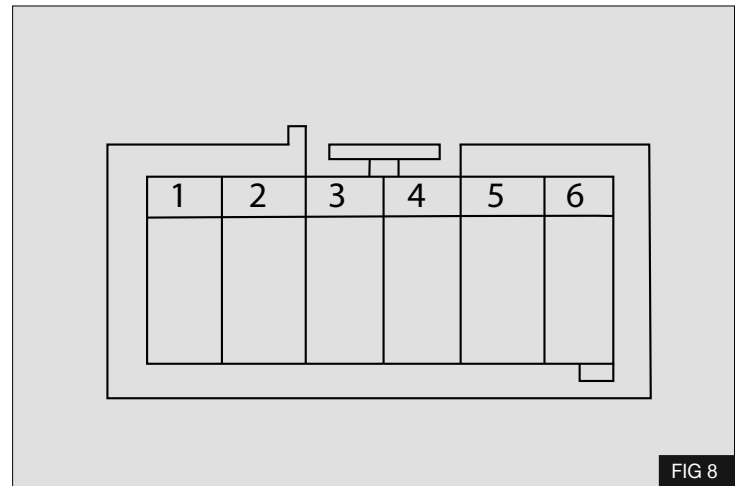

FIG 8

6 Way connector			
Ways	Connections	Allocation	
1	3ADJ	Accelerated idle control (wire cross-section 0.5mm <sup>2</sup> )	
2	BMT1	'Engine running' Information	Shared 10A Fuse (wire cross-section 1mm <sup>2</sup> )
3	SBP4	+ 12V Load shedding current distribution power supply	
4	MAN32	Earth (wire cross-section 1.5mm <sup>2</sup> )	
5		Reserve	
6		Reserve	

2 Way connector			
Ways	Connections	Allocation	
1	BP23	+12V Direct battery power supply for maximum consumption of a 40A (wire cross-section 7mm <sup>2</sup> ) 50A fuse F6 protection	
2	MAN32	Ground (wire cross-section 7mm <sup>2</sup> ) large enough to adapt to the battery +12V current	



(EN)

Techni focuses on constant upgrading of its products. The Manufacturer reserves the right to modify the models and components described in the present publication at any time for technical or commercial reasons and without prior notice. For further information, contact Techni technical services.

(DE)

Techni ist stets bestrebt die eigenen Produkte zu verbessern. Die Herstellerfirma behält sich das Recht vor, aus technischen oder Verkaufsgründen, zu jeder Zeit und ohne vorherige Ankündigung, Abänderungen an den Modellen und den in dieser Veröffentlichung beschriebenen Einbauteile vorzunehmen. Für weitere Informationen bitten wir Sie, sich an unseren Techni Kundendienst zu wenden.

(FR)

Techni vise à une amélioration constante des ces produits. La maison se réserve le droit d'apporter, à tout moment et sans préavis, des modifications aux modèles et aux composants décrits dans cette publication pour des raisons d'ordre technique ou commerciale. Pour d'ultérieures informations s'adresser au service d'assistance Techni.

(IT)

Techni mira ad un costante miglioramento dei propri prodotti. La Casa si riserva il diritto di apportare in qualunque momento e senza preavviso modifiche ai modelli e ai componenti descritti in questa pubblicazione per ragioni di natura tecnica o commerciale. Per ulteriori informazioni rivolgersi al servizio assistenza Techni.

(ES)

Techni aspira a un constante mejoramiento de su producción. La Fábrica se reserva el derecho de aportar en cualquier momento y sin preaviso modificaciones a los modelos y los componentes descritos en esta publicación por razones técnicas o comerciales. Para ulteriores informaciones dirigirse al servicio asistencia Techni.

VENDITA E SERVIZIO  
VENTE ET SERVICE

SALE AND SERVICE  
VERKAUF UND SERVICE



Sundorne Trade Park, Henley Way,  
Shrewsbury, United Kingdom, SY1 4NS  
Telephone (+44) (0) 1743 443176  
Fax (+44) (0) 1743 443113  
Email: [sales@techni.co.uk](mailto:sales@techni.co.uk)